



# **Instruction Manual**

## **LeCroy CP500**

### **Current Probe**

Revision D - February, 2008



## Warranty

LeCroy warrants this oscilloscope accessory for normal use and operation within specification for a period of one year from the date of shipment. Spare parts, replacement parts and repairs are warranted for 90 days.

In exercising its warranty, LeCroy, at its option, will either repair or replace any assembly returned within its warranty period to the Customer Service Department or an authorized service center. However, this will be done only if the product is determined by LeCroy's examination to be defective due to workmanship or materials, and the defect is not caused by misuse, neglect, accident, abnormal conditions of operation, or damage resulting from attempted repair or modifications by a non-authorized service facility.

The customer will be responsible for the transportation and insurance charges for the return of products to the service facility. LeCroy will return all products under warranty with transportation charges prepaid.

This warranty replaces all other warranties, expressed or implied, including but not limited to any implied warranty of merchantability, fitness or adequacy for any particular purposes or use. LeCroy shall not be liable for any special, incidental, or consequential damages, whether in contract or otherwise.

### Corporate Headquarters

700 Chestnut Ridge Road  
Chestnut Ridge, NY 10977-6499  
Tel: (845) 578-6020, Fax: (845) 578-5985

Internet: [www.lecroy.com](http://www.lecroy.com)

Copyright 2008 by LeCroy Corporation. All rights reserved.

LeCroy, ActiveDSO, JitterTrack, WavePro, WaveMaster, WaveSurfer, WaveLink, WaveExpert, WaveJet, and Waverunner are registered trademarks of LeCroy Corporation. Other product or brand names are trademarks or requested trademarks of their respective holders. Information in this publication supersedes all earlier versions. Specifications subject to change without notice.

CP500-OM-E Rev D (Note: This manual contains an updated Declaration of Conformity page. During this interim fix, the 915928-00 Rev A revision number shown here does not match the ones shown in the footers of this manual).

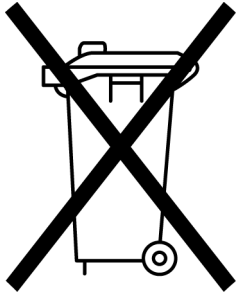
<p>Manufactured under an ISO 9000 Registered Quality Management System Visit <a href="http://www.lecroy.com">www.lecroy.com</a> to view the certificate.</p>	 <p>This electronic product is subject to disposal and recycling regulations that vary by country and region. Many countries prohibit the disposal of waste electronic equipment in standard waste receptacles. For more information about proper disposal and recycling of your LeCroy product, please visit <a href="http://www.lecroy.com/recycle">www.lecroy.com/recycle</a>.</p>
--	--





## DECLARATION OF CONFORMITY

according to ISO/IEC Guide 22 and EN 45014:1998

**Manufacturer's Name:** LeCroy Corporation

**Manufacturer's Address:** 700 Chestnut Ridge Road  
Chestnut Ridge, NY 10977  
USA

herewith declare that

**Product(s) Name:** Current Probe

**Model Number(s):** CP030, CP031, CP150, CP500

including all their options are in conformity with the provisions of the following EC directive(s), including the latest amendments, and with national legislation implementing these directives:

**73/23/EEC Low Voltage Directive**  
**89/336/EEC EMC Directive**

and that conformity with Council Directive 73/23/EEC is based on

EN 61010-2-032: 2002	Safety requirements for electrical equipment for measurement control and laboratory use
	Part2-032: Particular requirements for hand-held and hand-manipulated current sensors for electrical test and measurement

and that conformity with Council Directive 89/336/EEC is based on

EN 61326/A3:2003	EMC requirements for electrical equipment for measurement control and laboratory use	
Emissions	EN 55011/A2:2002	Conducted and Radiated Emissions
Immunity	EN 61000-4-2/A2:2001	Electrostatic Discharge
	EN 61000-4-3/A1:2003	RF Radiated Electromagnetic Field
	EN 61000-4-4:2004	Electrical Fast Transient/Burst
	EN 61000-4-5/A1:2001	Surge
	EN 61000-4-6/A1:2001	RF Conducted Electromagnetic Field

**By:** David C. Graef  
Vice President & Chief Technology Officer

**Place:** LeCroy Corporation  
700 Chestnut Ridge Road  
Chestnut Ridge, NY 10977  
USA

**Date:** December 18, 2007

**European Contact:**  
Your local LeCroy Sales Office or

LeCroy Europe GmbH  
Waldhofer Str 104  
D-69123 Heidelberg  
Germany

Tel: (49) 6221 82700  
Fax: (49) 6221 834655

**Warning: This is a Class A product. In a domestic environment this product may cause radio interference, in which case the user may be required to take adequate measures.**

BLANK PAGE

---

# Table of Contents



<b>Safety Information</b> .....	<b>1-1</b>
OPERATOR SAFETY .....	1-1
OPERATING ENVIRONMENT .....	1-1
SAFETY SYMBOLS .....	1-1
USAGE .....	1-2
<b>Overview</b> .....	<b>2-1</b>
DESCRIPTION .....	2-1
KEY FEATURES .....	2-1
CONVENTIONS USED IN THIS MANUAL .....	2-1
ACCESSORIES .....	2-2
<b>Operation</b> .....	<b>3-1</b>
PRECAUTIONS .....	3-1
CONNECTING THE PROBE TO THE TEST INSTRUMENT .....	3-1
CONNECTING THE PROBE TO THE TEST CIRCUIT .....	3-1
OPERATION WITH A LECROY OSCILLOSCOPE .....	3-2
AC COUPLING .....	3-3
AUTO ZERO .....	3-3
DEGAUSSING PROBE .....	3-4
INSERTION IMPEDANCE .....	3-4
<b>Care and Maintenance</b> .....	<b>4-1</b>
CLEANING .....	4-1
CLEANING CORE SURFACES .....	4-1
CALIBRATION INTERVAL .....	4-1
SERVICE STRATEGY .....	4-1
TROUBLESHOOTING .....	4-2
RETURNING A PROBE .....	4-2
RETURNING A PROBE TO A DIFFERENT COUNTRY .....	4-3
<b>Performance Verification</b> .....	<b>5-1</b>
TEST EQUIPMENT REQUIRED .....	5-1
PRELIMINARY PROCEDURE .....	5-2
FUNCTIONAL CHECK .....	5-2
PERFORMANCE VERIFICATION PROCEDURE .....	5-3
CHECK DC ACCURACY .....	5-3
<b>Specifications</b> .....	<b>6-1</b>



---

NOMINAL CHARACTERISTICS .....	6-1
WARRANTED CHARACTERISTICS .....	6-1
TYPICAL CHARACTERISTICS .....	6-1
ENVIRONMENTAL CHARACTERISTICS .....	6-2
PHYSICAL CHARACTERISTICS .....	6-2
COMPLIANCES AND CERTIFICATIONS .....	6-3
GRAPHS .....	6-4
<b>Appendix A .....</b>	<b>1-1</b>
PERFORMANCE VERIFICATION TEST RECORD .....	1-1
EQUIPMENT USED: .....	1-1
CP500 TEST RECORD .....	1-2

# Safety Information

## OPERATOR SAFETY

To avoid personal injury and to prevent damage to the probe or any products connected to it, review the following safety precautions.





## OPERATING ENVIRONMENT

Before using this probe, ensure that its operating environment will be maintained within these parameters:

Operation	In-door Use
Temperature	0 to 40 °C (32 to 104 °F)
Humidity	≤80% RH (non-condensing)

## SAFETY SYMBOLS

Whenever the following safety symbols appear in the instruction manual or on the probe, they alert the user to an aspect of safety.

Symbol	Meaning
	Refer to accompanying documents (for safety related information)
<b>CAUTION</b>	Calls attention to a procedure, practice or condition that could possibly cause damage to equipment
<b>WARNING</b>	Calls attention to a procedure, practice or condition that could possibly cause bodily injury or death
	Risk of electrical shock
	Earth ground
	Probe is protected by reinforced or double insulation

# CP500 Current Probe

---

## USAGE

The probe is intended to be used only with instruments that are connected to earth ground through the input connector. The probe is not intended to be used in wet or explosive atmospheres.



The use of the probe and/or the instrument it is connected to in a manner other than that specified may impair the safety mechanisms.



In order to assure safe operation and to obtain maximum performance from the unit, observe the following:

1. To avoid short circuits and accidents that could result in injury or death, use the CP500 current probe only with conductors carrying 600 V (CAT II) or 300 V (CAT III) or less.
2. In order to prevent short circuits and electric shock when conductors being measured carry less than 600 V (CAT II) or 300 V (CAT III) but more than the safe voltage level (SELV-E) make sure that the conductors to be measured are insulated with material conforming to:
  - Overvoltage Category III  
Basic insulation requirement for working voltage of 300 V.
  - Pollution degree 2
3. Never install or remove the probe on bare conductors which are energized. The transformer core and shield are grounded but not insulated and may contact the conductor when the locking lever is open.
4. Be careful not to damage the insulation surface when making measurements.
5. Do not use the probe if any part is damaged. All maintenance should be referred to qualified service personnel.



To guarantee accurate performance characteristics, mechanical shock should be avoided, as well as damage to the cable through excessive bending. The probe case is not sealed and should never be immersed in any fluid. Do not exceed the maximum specified current/voltage levels. (See Specifications).

###



# Overview

## DESCRIPTION

The CP500 uses a combination of Hall effect and transformer technology which enables measurements to be made on DC, AC and impulse currents. It has a 2 MHz bandwidth and is designed to measure continuous currents up to 500 Amp.

The probe can be used with a Waverunner®, WavePro®, or LC series oscilloscope with firmware 9.1.0 or higher. With the ProBus interface, the CP500 becomes an integral part of the oscilloscope. The bandwidth limit, auto zero and degauss functions are all controlled from the oscilloscope's front panel. The oscilloscope provides power to the probe, so no external power supply is needed.

## KEY FEATURES

- Highly accurate current measurements
- Easy current measurements
- Large opening for high current measurements
- Compact
- Over-current protected

## CONVENTIONS USED IN THIS MANUAL

The following conventions may appear in this manual:

### **Note**

*A Note contains information relating to the use of the product.*

### **CAUTION**

*A Caution contains information that should be followed to avoid possible damage to the instrument or the device under test.*

### **WARNING**

*A Warning alerts you to a potential hazard. Failure to adhere to the statement in a WARNING message could result in personal injury.*

## CP500 Current Probe

---

### ACCESSORIES

Certificate of Calibration

Instruction Manual.

CP500-OM-E

###

# Operation

## PRECAUTIONS

### Note

*The sensor head is a precision assembly consisting of a molded component with a ferrite core and a Hall effect element. It may be damaged if subjected to sudden changes in temperature, mechanical strain or shock.*

*The mating surfaces of the sensor are precision ground and should be treated with care. If there is any type of dust or dirt on the mating surfaces of the sensor head, measurements may be impaired.*

### Note

*Accurate measurements may not be possible in locations subject to strong magnetic fields such as transformers and high-current conductors, or in locations subject to strong external electric fields.*

## CONNECTING THE PROBE TO THE TEST INSTRUMENT

The CP500 probe has been designed for use with the Waverunner, WavePro and LC series LeCroy oscilloscopes equipped with the ProBus interface. Attach the probe output connector to the oscilloscope input connector. The oscilloscope will recognize the probe, set the oscilloscope input termination to 1 M $\Omega$  and activate the probe control functions in the user interface.

## CONNECTING THE PROBE TO THE TEST CIRCUIT

The CP500 has been designed with a movable split core, eliminating the need to break the conductor for the core to slip around the conductor.

To connect:

1. Pull the locking lever towards the cable so that the clamp opens.
2. Align the sensor so that the current direction indicator corresponds to the direction of current flow in the conductor.

## CP500 Current Probe

---

3. Press the probe jaws together around the conductor until the jaws click shut.
4. Slide the locking lever on the sensor head towards the front of the probe until the "UNLOCK" indication disappears and the "LOCK" indication appears.

### **Note**

*Never use this probe on bare conductors. The core and shield are grounded and any voltage applied to the conductor may cause damage the probe or the circuit under test.*

## OPERATION WITH A LECROY OSCILLOSCOPE

### **Note**

*Proper operation of the CP500 requires software version 9.1.0 or higher. Attaching the probe to an oscilloscope with older software may give unreliable operation, including lock up of the oscilloscope. Should this occur, remove the probe and turn the oscilloscope power OFF and ON. The verify the software version by pressing SCOPE STATUS and selecting the SYSTEM menu choice. Software upgrades for most LeCroy oscilloscopes can be obtained free of charge. Contact your LeCroy sales representative for more information.*

Control through the oscilloscope user interface can be found in the **Coupling** menu of the channel to which the probe is connected.

Turning the **VOLTS/DIV** knob will control the oscilloscope's scale factor to give full dynamic range. The minimum and maximum sensitivities depend on the oscilloscope being used.

Figure 3-1 shows the oscilloscope user interface menu for a CP500 probe.

The menu allows for the selection of the probe's coupling (**DC**, **Grounded** or **AC**) in the **COUPLING** menu, **DEGAUSS PROBE** and **AUTO ZERO** functions.

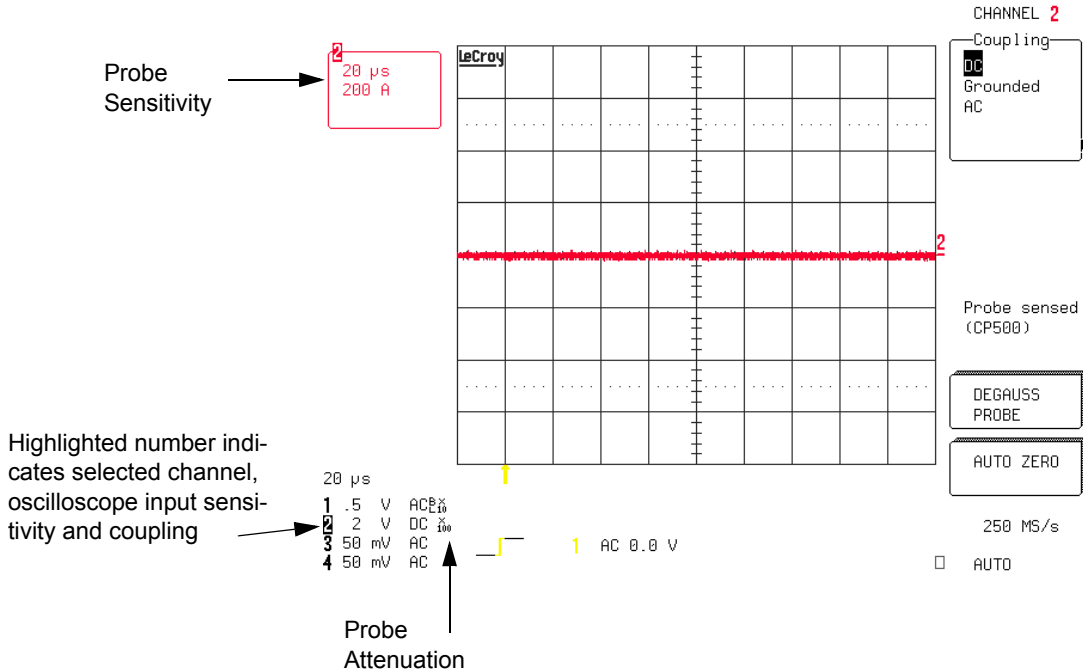

Fig. 3-1. Oscilloscope display with menu

AC COUPLING

DC, Ground or AC coupling can be selected through the Coupling menu. AC coupling occurs at the input of the oscilloscope and not at the probe input. When using the CP500 in the AC coupling mode and measuring AC signals with a DC component, care must be taken to assure that the dynamic range of the probe will not be exceeded. There will be no warning if the dynamic range is exceeded. If clipping of the waveform occurs, check to see if the operating range of the probe has been exceeded. This can be done by changing the coupling back to DC and setting the scale factor to the maximum Amp/Div.

AUTO ZERO

The CP500 incorporates an Auto Zero function to remove the DC offset from the current probe. Auto Zero must be invoked by the user. After several minutes of warm-up, or when the probe is exposed to a large shift in ambient temperature, some DC offset

## CP500 Current Probe

---

drift may occur. To initiate an Auto Zero cycle press the button next to **AUTO ZERO** menu in the oscilloscope's user interface. Auto Zero must be performed without any current passing through the test conductor and with a correctly closed probe head.

### DEGAUSSING PROBE

If the probe has been magnetized by external magnetic field or by prolonged exposure to non-symmetrical pulsed currents resulting in a DC offset, the core can be demagnetized by pressing the button next to **DEGAUSS PROBE** menu in the user interface.

Prior to use, the CP500 probe should be degaussed to eliminate any residual magnetization from the probe core. Residual magnetism in the core is a major cause of measurement errors when used at high sensitivities.

The demagnetizing process takes about 5 seconds and should always be performed before taking a measurement.

Without clamping the probe around a conductor, slide the opening lever to close and lock the probe and press the button next to **DEGAUSS PROBE** menu twice

An Auto Zero is automatically performed as part of the degauss cycle.

#### **Note**

*Never install or remove the probe on bare conductors which are energized. The transformer core and shield are grounded but not insulated and may contact the conductor when the locking lever is open.*

Degauss the probe in any of these cases:

- After turning on the oscilloscope and probe
- After connecting the probe to the oscilloscope
- Before connecting the probe to the circuit under test
- Whenever an overload conditions occurred
- Whenever the probe is subjected to strong magnetic fields

### INSERTION IMPEDANCE

Connecting a current probe to a circuit under test may alter the characteristics of this circuit because of the impedance represented by the current probe.

# Operation

In the case of an AC current probe, or open loop AC/DC current probe, two elements are added: the leakage inductance and magnetizing inductance shunted with a small resistance. Refer to Figure 3-2 A

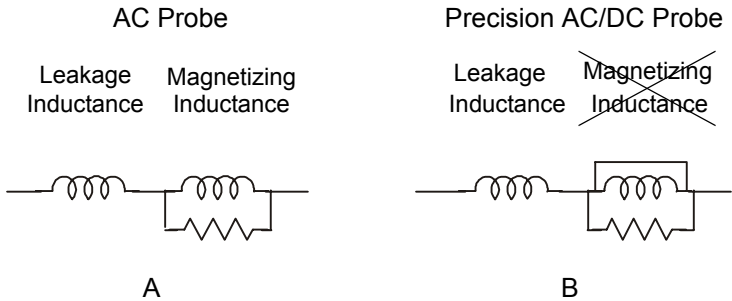

**Figure 3-2. Insertion Impedance**

In a closed loop AC/DC current probe, the magnetizing inductance term drops out because the bucking coil prevents the core from being magnetized. Figure 3-2 B.

In addition to the impedance resulting from probe insertion, any loop wire added to the conductor to gain access to the conductor will increase the total impedance of the conductor.

###

## CP500 Current Probe

---

BLANK PAGE



# Care and Maintenance

## CLEANING

The exterior of the probe and cable should be cleaned only using a soft cloth moistened with water or isopropyl alcohol. The use of abrasive agent, strong detergents or other solvents may damage the probe.

### **CAUTION**



*The probe case is not sealed and should never be immersed in any fluid.*

## CLEANING CORE SURFACES

To clean the transformer core surfaces, open the locking lever and clean the exposed core surfaces with a cotton swab dampened with isopropyl or ethyl alcohol.

In no case should the core surfaces be lubricated. Any lubrication between the mating surfaces will degrade the performance of the current probe should be removed with isopropyl or ethyl alcohol.

## CALIBRATION INTERVAL

The recommended calibration interval is one year. Adjustment should only be performed by qualified personnel. (A Performance Verification procedure is included in this manual.)

## SERVICE STRATEGY

Defective probes must be returned to a LeCroy service facility for diagnosis and exchange. A defective probe under warranty will be replaced with a factory refurbished probe. A probe that is not under warranty can be exchanged for a factory refurbished probe. A modest fee is charged for this service. A defective probe must be returned in order to receive credit for the probe core.

Calibration adjustments require the use of specialized signal sources which are not commercially available. Probes which do not pass the performance verification must be returned to the factory for service.

## CP500 Current Probe

---

### TROUBLESHOOTING

If the probe is not operating properly the problem may be the way in which it is used. Before assuming the probe is defective, perform the following troubleshooting procedures:

1. Verify using on a LT or LC series LeCroy oscilloscope with firmware 9.1.0 or higher. (Firmware version of your oscilloscope can be verified by pushing **SCOPE STATUS** and then selecting **System** menu option.)
2. Waveform is inverted — Make sure the arrow on the core clamp is in the direction of the current flow.
3. If the displayed signal shows a high offset — The probe locking lever may not be fully closed and locked or the probe may need to be degaussed.
4. Attenuated signals or poor frequency response may be caused by contaminated core surfaces or the probe locking lever may not be fully closed and locked.
5. No signal — Make sure the locking lever is closed and locked and verify that the ProBus connector is fully engaged

### RETURNING A PROBE

The procedure for returning a probe for calibration or service is as follows:

Contact your local LeCroy sales representative to find out where to return the product. All returned products should be identified by model number and serial number. Provide your name and contact number and if possible describe the defect or failure. In case of products returned to the factory, a Return Authorization Number (RAN) should be used. The RAN can be established by contacting your nearest LeCroy sales office, representative, or the North America Customer Care Center.

Return shipment should be prepaid. LeCroy cannot accept COD or Collect Return shipments. We recommend air-freighting. It is important that the RAN be clearly shown on the outside of the shipping package for prompt redirection to the appropriate department.

1. Contact your local LeCroy sales or service representative to obtain a Return Authorization Number.
2. Remove all accessories from the probe. Do not include the manual.

## Care and Maintenance

---

3. Pack the probe in its case, surrounded by the original packing material (or equivalent) and box.
4. Label the case with a tag containing:
  - The RAN
  - Name and address of the owner
  - Probe model and serial number
  - Description of failure
5. Package the probe case in a cardboard shipping box with adequate padding to avoid damage in transit.
6. Mark the outside of the box with the shipping address given to you by the LeCroy representative; be sure to add the following:
  - ATTN: <RAN assigned by the LeCroy representative>
  - FRAGILE
7. Insure the item for the replacement cost of the probe.
8. Ship the package to the appropriate address.

### RETURNING A PROBE TO A DIFFERENT COUNTRY

In order to avoid customs duty for purchase price of a new probe, when your probe is returned for service, please use the following procedure.

In addition to the items mentioned above in 'Returning a Probe', you'll need to mark shipments returned for service as a 'Return of US goods for warranty repair/recalibration'. If there is a cost involved in the service, put the cost of the service in the value column and the original value of the product at time of purchase in the body of the invoice marked 'For insurance purposes only'. Be very specific as to the reason for shipment.

Duties may have to be paid on the value of the service.

####

## CP500 Current Probe

---

BLANK PAGE

# Performance Verification

This procedure can be used to verify the warranted characteristics of the CP500 Current Probe.

The recommended calibration interval for the model CP500 Current Probe is one year. The complete performance verification procedure should be performed as the first step of annual calibration. Test results can be recorded on a photocopy of the Test Record provided at the end of the manual.

Performance verification can be completed without removing the probe covers or exposing the user to hazardous voltages.

Calibration adjustments require the use of specialized signal sources which are not commercially available. Probes which do not pass the performance verification must be returned to the factory for service.

Adjustment should only be performed by qualified personnel.

## TEST EQUIPMENT REQUIRED

The following table lists the test equipment and accessories (or their equivalents) which are required for performance verification of the CP500 Current Probe.

Because the input and output connector types may vary on different brands and models of test instruments, additional adapters or cables may be required.

**Table 5-1. List of Required Equipment**

Description	Minimum Requirements	Test Equipment Examples
Oscilloscope	Any oscilloscope equipped with ProBus interface with software version 9.1.0 or higher	LeCroy LT322
Digital Multimeter (2 required)	DC: 0.1% Accuracy 5½ digit resolution	Agilent Technologies 34401A or Fluke 8842A-09
Function Generator	50 Hz sine wave output. 3 Vrms into 50Ω	Agilent Technologies 33120A or Stanford Research Model DS340
Calibration Fixture, 500 turn Loop	500 turn loop in series with 0.5Ω ± 0.1% resistor with sense terminals.	LeCroy CP150-CF02

## CP500 Current Probe

---

Description	Minimum Requirements	Test Equipment Examples
Calibration Fixture	ProBus Extension Cable	LeCroy PROBUS-CF01
Banana Plug Adapter	Female BNC to Dual Banana Plug	Pomona 1269
Patch Cables (4 required)	Male Banana to Male Banana, 12"	Pomona B-12-0 (black), B-12-2 (red)
BNC Adapter	BNC Male to Dual Banana Jack	Pomona 1296

### PRELIMINARY PROCEDURE

1. Connect the CP500 to the channel 1 input of the oscilloscope and completely close the probe locking lever.
2. Turn the oscilloscope on and allow at least 30 minutes warm-up time for the CP500 and test equipment before performing the Verification Procedure.
3. Turn on the other test equipment and allow these to warm up for the time recommended by the manufacturer.
4. While the instruments are reaching operating temperature, make a photocopy of the Performance Verification Test Record (located in Appendix A), and fill in the necessary data.

### FUNCTIONAL CHECK

The functional check will verify the basic operation of the probe functions.

It is recommended that the Functional Check be performed prior to the Performance Verification Procedure.

1. Select Channel 1 and enter the **Coupling** menu and verify that the probe BWL is set to **OFF**.
2. Verify that **Probe sensed (CP500)** is displayed on the right hand menu.
3. Degauss the probe by pressing the **DEGAUSS** button, (located in the coupling menu), twice.
4. Verify that "**Performing Degauss and Auto Zero on CP500 probe...**" is displayed at the top of the screen and no error message remains displayed.
5. Lock the probe by pushing the locking slider fully towards the probe head.

## Performance Verification

---

6. Verify that the message disappears.
7. Degauss the probe by pressing the **DEGAUSS** button, (located in the Coupling menu), twice.
8. Verify that “**Degaussing CP500 probe...**” is displayed at the top of the screen and no error message remains displayed.

### PERFORMANCE VERIFICATION PROCEDURE

The warranted characteristics of the CP500 Current Probe are valid at any temperature within the Environmental Characteristics listed in the Specifications. However, some of the other test equipment used to verify the performance may have environmental limitations required to meet the accuracy needed for the procedure. Make sure that the ambient conditions meet the requirements of all the test instruments used in his procedure.

#### **Note**

*The correct operation of the CP500 controls requires software version 9.1.0 or higher. The software version in the test oscilloscope can be verified by pushing **SCOPE STATUS**, then selecting the **System** menu option. Contact your local LeCroy representative if the software in your oscilloscope requires updating.*

### CHECK LF ACCURACY

1. Set the Function generator to 50 Hz sine wave. Output voltage at 3 Vrms with 50 $\Omega$  output.
2. Remove the CP500 from the oscilloscope and reconnect using the ProBus extension cable. Connect the BNC male connector of the ProBus extension to DMM #1 using a BNC Female to Dual Banana adapter. Refer to figure 5-1.
3. Using Banana Patch cords and the BNC to Dual Banana Plug adapter, connect the 'V Source' and 'V Return' terminals of the 500 turn Calibration Loop to the output of the Function Generator.
4. Connect the Current Sense terminals of the 500 turn Calibration Loop to the voltage inputs of DMM #2.
5. Set both DMMs to measure AC Volt.
6. Remove the CP500 from the oscilloscope and reconnect using the ProBus extension cable. Connect the BNC male

## CP500 Current Probe

connector of the ProBus extension to DMM #1 using a BNC Female to Dual Banana adapter.

7. Remove the CP500 from the oscilloscope and reconnect using the ProBus extension cable. Connect the BNC male connector of the ProBus extension to DMM #1 using a BNC Female to Dual Banana adapter.

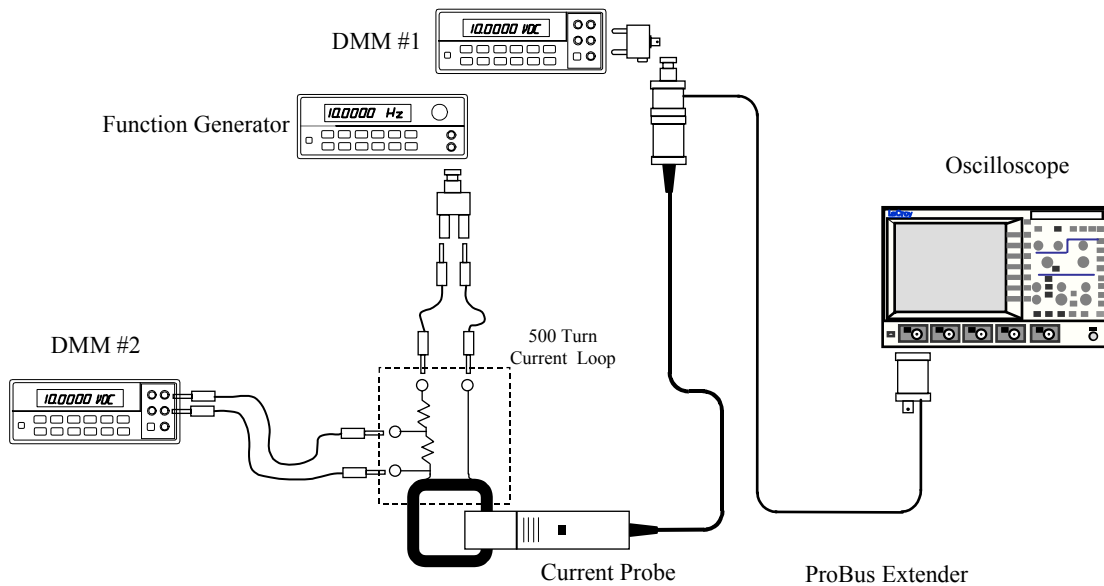

**Figure 5-1. LF Accuracy Test Set Up**

8. Using Banana Patch cords and the BNC to Dual Banana Plug adapter, connect the 'V Source' and 'V Return' terminals of the 500 turn Calibration Loop to the output of the Function Generator.
9. Connect the Current Sense terminals of the 500 turn Calibration Loop to the voltage inputs of DMM #2.
10. Set both DMMs to measure AC Volt.
11. With the CP500 removed from any signal and the locking lever returned to the LOCKED position, degauss the probe by pressing the **DEGAUSS** button (located on the coupling menu) twice.
12. Open the CP500 locking lever and position the probe input



## Performance Verification

---

around the 500 turn loop. Close and LOCK the locking lever.

13. Adjust the Function generator voltage until the voltage measured at the 'Current Sense' terminals (DMM #2) reads  $500 \text{ mV} \pm 0.05 \text{ mV}$ . (This corresponds to 500 A at the probe head).
14. Record the voltage measured by DMM #1 on the Test Record.
15. Verify that the measured voltage is between 0.495 Volt and 0.505 Volt.

###

## CP500 Current Probe

---

BLANK PAGE

# Adjustment Procedure

This procedure can be used to adjust the warranted characteristics of the CP500 Current Probe. This procedure should be used if a parameter measured in the Performance Verification Procedure is outside of the specification limits.

Adjustment should only be performed by qualified personnel.

## TEST EQUIPMENT REQUIRED

The following table lists the test equipment and accessories, or their equivalents, which are required for adjustment of the CP500 Current Probe.

Because the input and output connector types may vary on different brands and models of test instruments, additional adapters or cables may be required.

Description	Minimum Requirements	Test Equipment Examples
Wide Band Oscilloscope	ProBus interface equipped Software version 8.6.0 or higher	LeCroy LT322
Digital Multimeter (2 required)	DC: 0.1% Accuracy 5½ digit resolution	Agilent Technologies 34401A, or Fluke 8842A-09
Function Generator	50 Hz sine wave output. 3 Vrms into 50 Ω	Agilent Technologies 33120A, or Stanford Research Model DS340
Calibration Fixture, 50 Turn Loop	500 Turn loop in series with 0.5 Ω ±0.1% resistor with sense terminals.	LeCroy CP150-CF02
Calibration Fixture	ProBus Extension Cable	LeCroy PROBUS-CF01
Banana Plug Adapter	Female BNC to Dual Banana Plug	Pomona 1269
Patch Cables (4 required)	Male Banana to Male Banana, 12"	Pomona B-12-0 (black), B-12-2 (red)
BNC Adapter	BNC Male to Dual Banana Jack	Pomona 1296
Double-sided tape	Adhesive tape to re-attach probe label	Scotch Double Stick Tape 0.5" wide

## ADJUSTMENT PROCEDURE

The warranted characteristics of the CP500 Current Probe are valid at any temperature within the Environmental Characteristics listed in the Specifications. However, some of the other test equipment used to verify the performance may have environmental limitations required to meet the accuracy needed

## CP500 Current Probe

---

for the procedure. Make sure that the ambient conditions meet the requirements of all the test instruments used in this procedure.

**Note:**

*The correct operation of the controls of the CP500 requires oscilloscope software version 8.6.0 or higher. The software version in the test oscilloscope can be verified by pushing **SCOPE STATUS**, then selecting the **System** menu option. Contact your local LeCroy representative if the software in your oscilloscope requires updating.*

### PRELIMINARY PROCEDURE

1. *Here: How to open compensation box.*
2. Connect the CP500 to the channel 1 input of the oscilloscope through the ProBUS extension cable, and close and lock the probe jaws.
3. Turn the oscilloscope on and allow at least 30 minutes warm-up time for the CP500 and test equipment before performing the Verification Procedure.

### ADJUST LF ACCURACY.

1. Set the Function Generator to 50 Hz, sinewave output at 1.7 Vrms with 50  $\Omega$  output.
2. Connect BNC male of ProBus extension to DMM #1 using BNC Female to Dual Banana adapter.
3. Using banana patch cords, connect the 'V Source' and 'V Return' terminals of the 500 Turn Calibration Loop, to the output of the Function Generator using the BNC to Dual Banana plug adapter Output. (Refer to Figure 5-1).
4. Connect the Current Sense terminals of the 500 Turn Calibration Loop to the voltage inputs of DMM #2.

## Adjustment Procedure

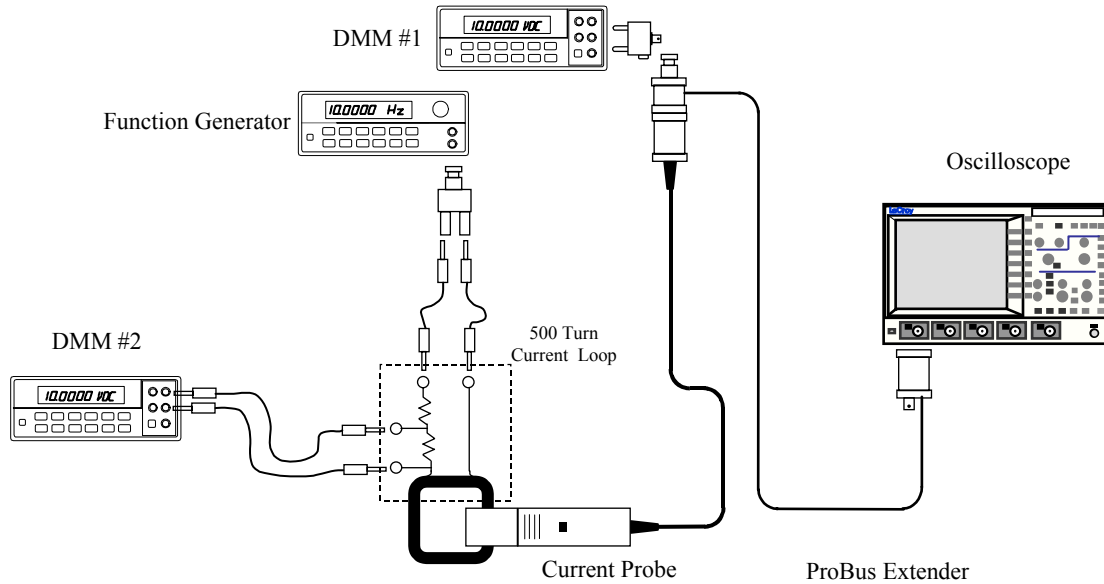

**Figure 5-1. LF Accuracy Adjustment Set Up**

5. Set both DMMs to measure AC Volt.
6. With the CP500 removed from any signal and the slider returned to the LOCKED position, degauss the probe by pressing the **DEGAUSS** button on the oscilloscope, (located on the coupling menu), twice.
7. Open the CP500 jaws and position the probe input around the 500 Turn loop. Close and LOCK the slider.
8. Adjust the Function Generator voltage until the voltage measured at the 'Current Sense' terminals (DMM #2) is  $500 \text{ mV} \pm 0.05 \text{ mV}$ . (This corresponds to 500 A at the probe head).
9. Adjust variable resistor VR202 until the voltage measured on DMM #1 is close to 10X the voltage measured on DMM #2.
10. Verify that the measured voltage is between 0.495 V and 0.505 V.
11. Disconnect the probe from the test set-up.

## CP500 Current Probe

---

12. Re-apply the light blue product label to the probe head using the double-sided tape.

###

# Specifications

## NOMINAL CHARACTERISTICS

Nominal characteristics describe parameters and attributes that are guaranteed by design, but do not have associated tolerances.

Maximum Continuous Input Current	500 A <sub>rms</sub> Refer to Figure 7-1, "Input current vs. frequency"
Maximum Peak Input Current	700 Amp peak
Intended Output Load	1 MΩ
Maximum Permitted Circuit Voltage	600 V Cat II, 300 V Cat III (Insulated conductor).

## WARRANTED CHARACTERISTICS

Warranted characteristics describe parameters that have guaranteed performance. Unless otherwise noted, tests are provided in the Performance Verification Procedure for all warranted specifications.

Guaranteed at 23 °C ±3 °C (73 °F ±5 °F) after power has been applied for 30 minutes.

Low Frequency Accuracy	
0 to 500 Amp	±1% of reading ±500 mA
500 to 700 Amp peak	±2% of reading

## TYPICAL CHARACTERISTICS

Typical characteristics describe parameters that do not have guaranteed performance, however, are representative of the average performance from a sample of several probes. Tests for typical characteristics are not provided in the Performance Verification procedure.

Sensitivity*	200 mA/div* to 200 A/div
Scale Factor Temperature Coefficient	±2% or less. (from 0 to +40 °C, 32 °F to 104 °F).

\* Lower sensitivity may change with different oscilloscope models.

## CP500 Current Probe

---

Noise	Equivalent to 25 mA <sub>rms</sub> or less (Bandwidth of measuring instrument: 20 MHz).
Insertion Impedance	Refer to Figure 7-2.
Bandwidth (-3 dB)	DC to 2 MHz
Rise Time	≤ 175 ns

### ENVIRONMENTAL CHARACTERISTICS

Temperature: Operating	0 to 40 °C (32 °F to 104 °F) at ≤ 80% relative humidity.
Storage	-10 °C to 50 °C (14 °F to 122 °F) ≤ 80% relative humidity.
Usage	Indoor
Altitude	2000 m (6562 ft).
Effect of External Magnetic Field	Equivalent to a maximum of 800 mA (In a DC or 60 Hz, 400 A/m magnetic field).

### PHYSICAL CHARACTERISTICS

Dimensions Probe:	
Length	176 mm (6.9 in.)
Width	27 mm (1.1 in.)
Height	69 mm (2.7 in.)
Dimensions Compensation Box:	
Length	65 mm (2.6 in.)
Width	39 mm (1.5 in.)
Height	24 mm (0.9 in.)
Weight	650 g (22.9 oz.)
Maximum conductor diameter	20 mm (0.79 in.)
Cable length	6 m (19.6 ft)



### COMPLIANCES AND CERTIFICATIONS

#### CE Declaration of Conformity

The probe meets requirements of the EMC Directive 89/336/EEC for Electromagnetic Compatibility and Low Voltage Directive 73/23/EEC for Product Safety.

EMC Directive:	EN 61326:1997+A1:1998+A2:2001+A3:2003 EMC requirements for electrical equipment for measurement, control and laboratory use
Electromagnetic Emission:	EN 55011:1998+A2:2002 Radiated Emissions (Class B)
Electromagnetic Immunity:	EN 61000-4-2:1995+A2:2001* Electrostatic Discharge (4 kV/8 kV contact/air)  EN 61000-4-3:2002+A1:2003* RF Radiated Electromagnetic Field (3 V/m)
Low Voltage Directive:	EN 61010-2-032:2002 Safety requirements for electrical equipment for measurement control and laboratory use. Part 2-032: Particular requirements for hand-held and hand-manipulated current sensors for electrical test and measurement  The probe has been qualified to the following limits: Measurement Category II, III (anticipated transient voltage 4000 V) Pollution Degree 2

\*Meets Performance Criteria "B" limits at certain test levels, during the disturbance, product undergoes a temporary degradation or loss of function of performance which is self recoverable.

# CP500 Current Probe

## GRAPHS

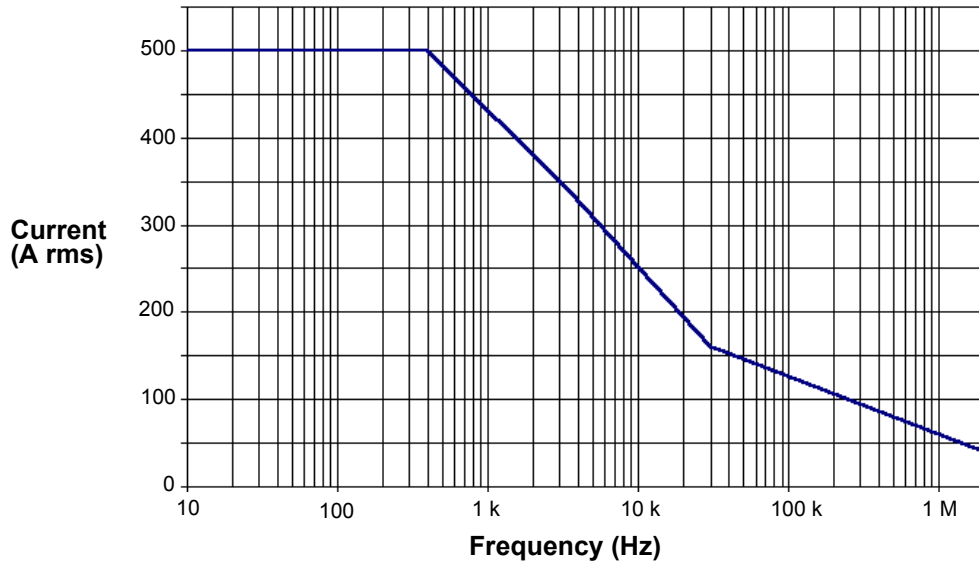

Figure 7-1. Maximum Input Current vs. Frequency

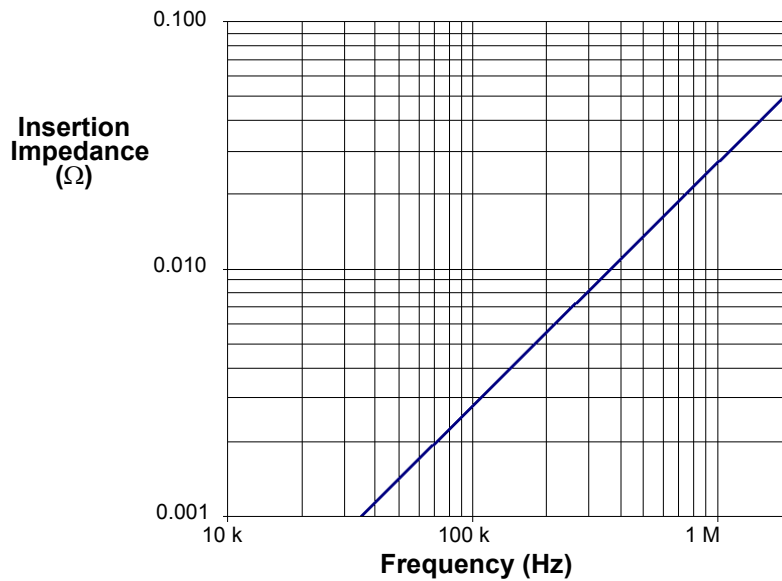

Figure 7-2. Insertion Impedance vs. frequency

###

# Appendix A

## PERFORMANCE VERIFICATION TEST RECORD

This record can be used to record the results of measurements made during the performance verification of the CP500 Current Probe.

Photocopy this page and record the results on the copy. File the completed record as required by applicable internal quality procedures.

The section in the test record corresponds to the parameters tested in the performance verification procedure. The numbers preceding the individual data records correspond to the steps in the procedure that require the recording of data. Results to be recorded in the column labeled "Test Result" are the actual specification limit check. The test limits are included in all of these steps. Other measurements and the results of intermediate calculations that support the limit check are to be recorded in the column labeled "Intermediate Results".

Permission is granted to reproduce these pages for the purpose of recording test results.

**Model:** CP500

**Serial Number:** \_\_\_\_\_

**Asset or Tracking Number:** \_\_\_\_\_

**Date:** \_\_\_\_\_

**Technician:** \_\_\_\_\_

### EQUIPMENT USED:

	MODEL	SERIAL NUMBER	CALIBRATION DUE DATE
Digital Multimeter			
Digital Multimeter			
Function Generator <sup>1</sup>			N/A

<sup>1</sup>The function generator used in this Performance Verification Procedure is used for making relative measurements. The output of the generator is measured with a DMM or oscilloscope in this procedure. Thus, the generator is not required to be calibrated.

## CP500 Current Probe

---

### CP500 TEST RECORD

Step	Description	Test Result
<b>Gain Accuracy</b>		
14	Probe Output (Spec Limit: 0.495 - 0.505 V)	_____ V

###